

ROOM# 1043
LIVING ROOM

1 PLAN: SERPENTINE DESK @ LIVING ROOM # 1043
3.42 SCALE: 3/4" = 1' ARCH. REF.: 1/A-565-O

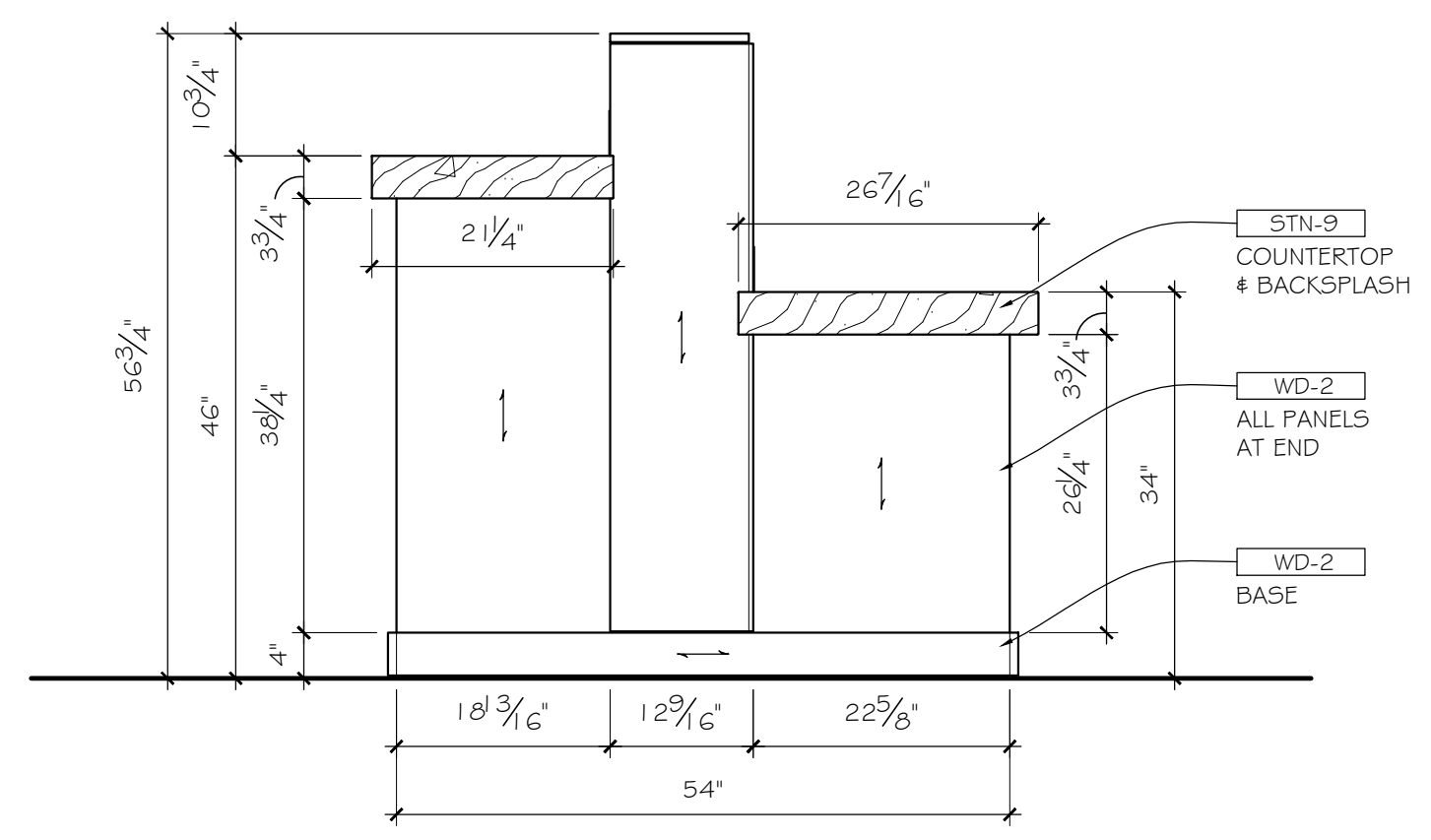

2 ELEVATION:
3.42 SCALE: 3/4" = 1' ARCH. REF.: 6/A-565-O

INSTITUTIONAL

blacks outsourcing, inc.
Architectural Woodwork Engineering
Our business is drawing yours

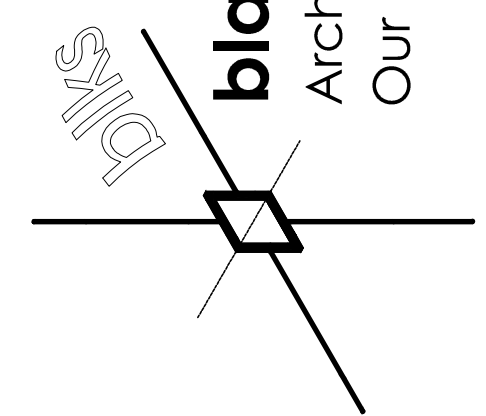

2-3.42

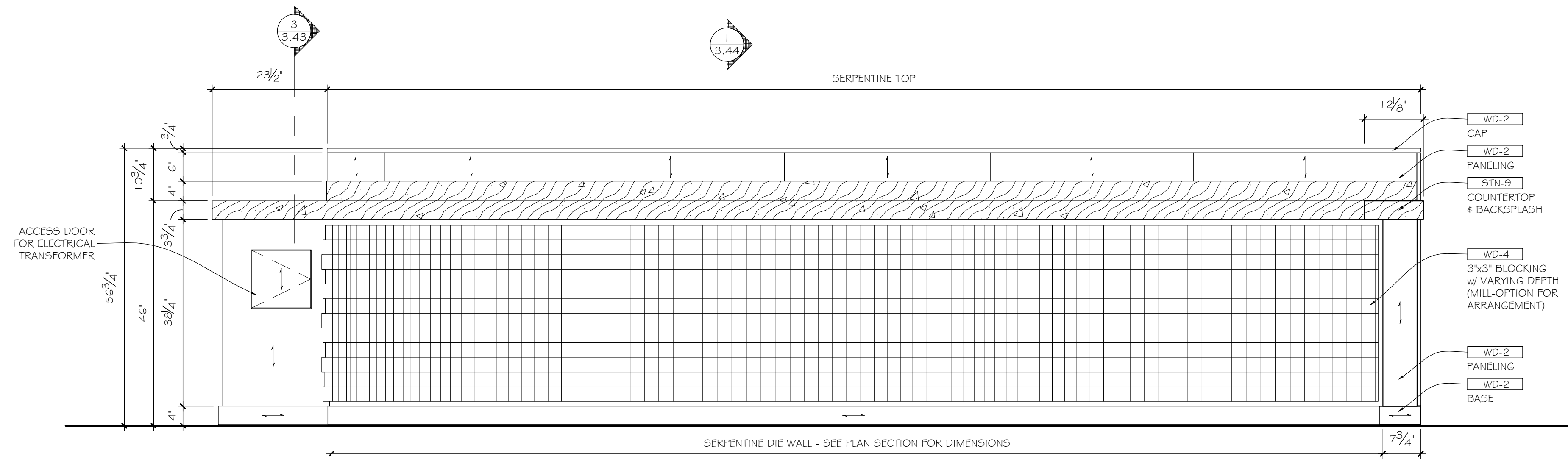

1 ELEVATION:
3.43 SCALE: 3/4"=12" ARCH. REF.: 3/A-565-0

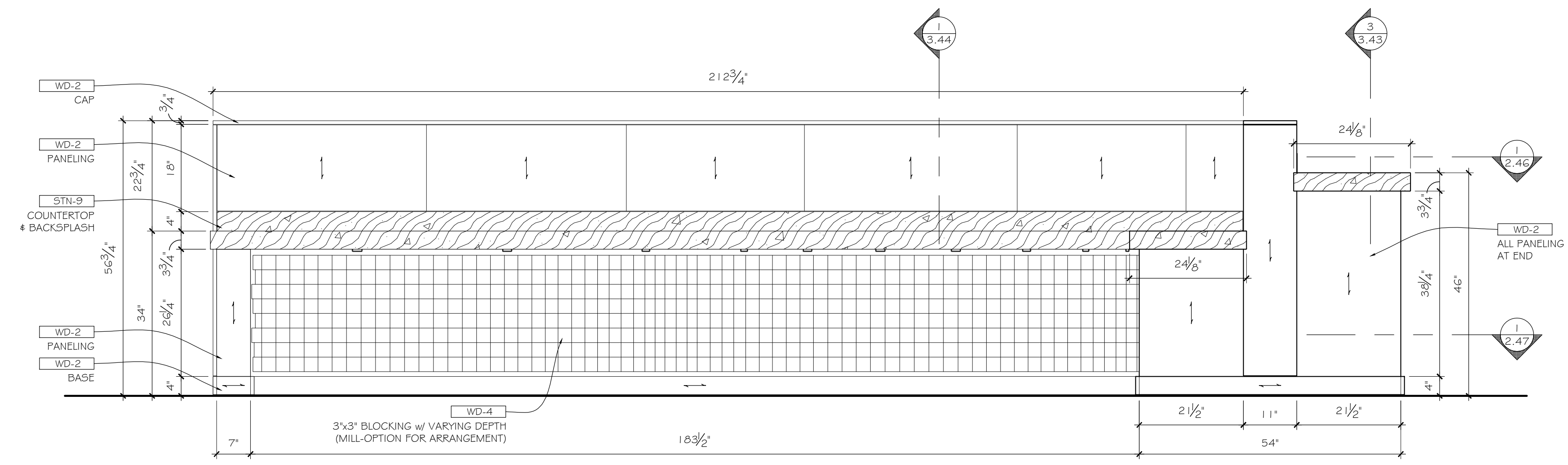

2 ELEVATION:
3.43 SCALE: 3/4"=12" ARCH. REF.: 5/A-565-0

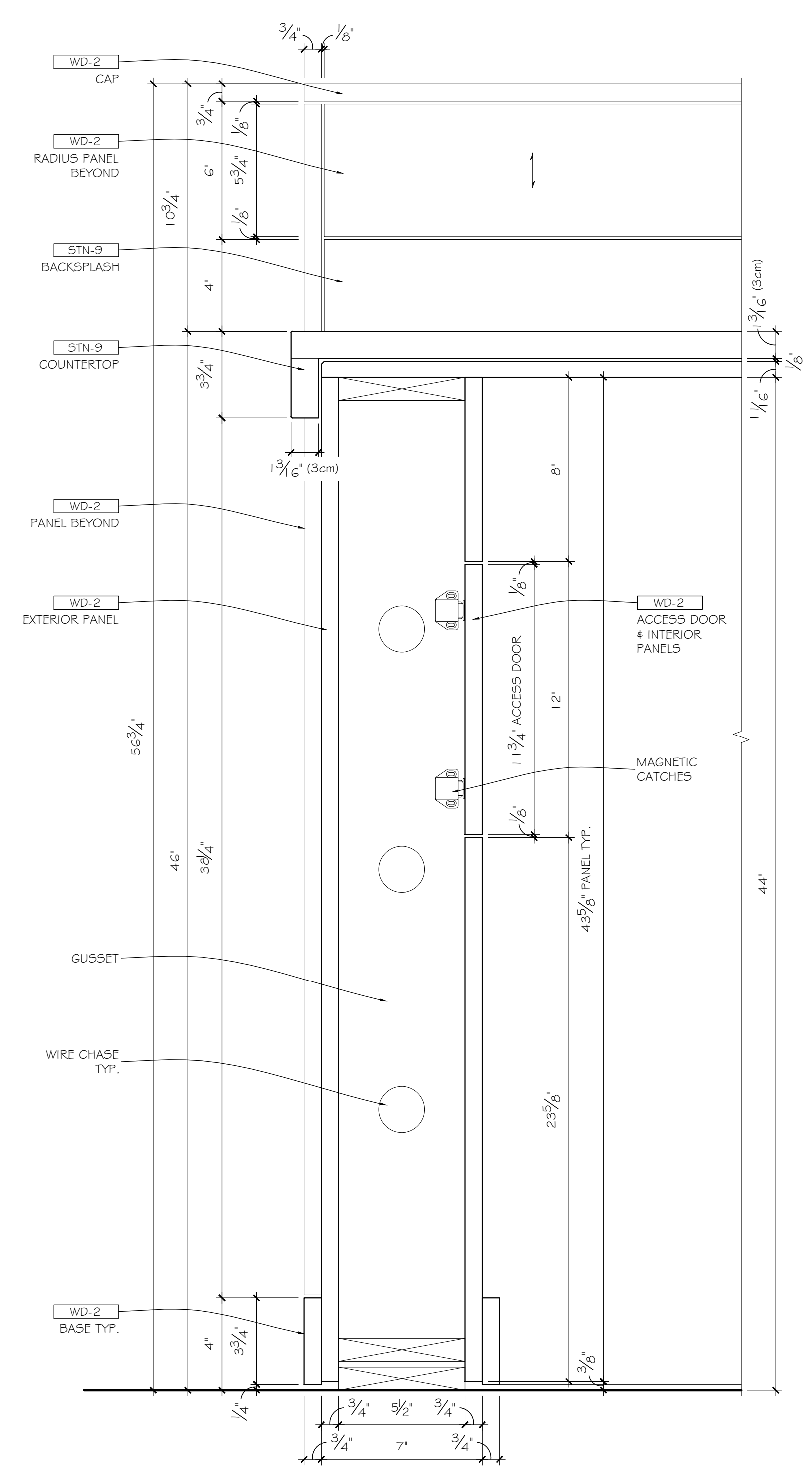

3 SECTION:
3.43 SCALE: 3"=12" ARCH. REF.: 1/OA-565-0

INSTITUTIONAL

blacks outsourcing, inc.
Architectural Woodwork Engineering
Our business is drawing yours

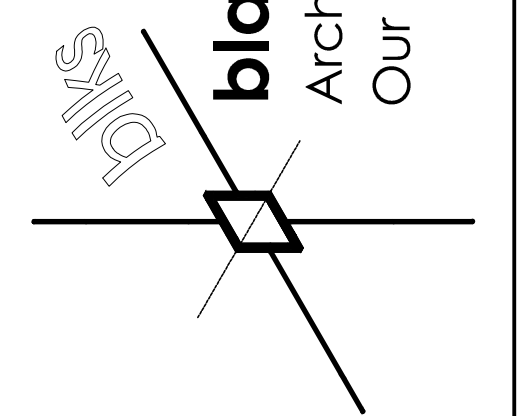

2-3.43

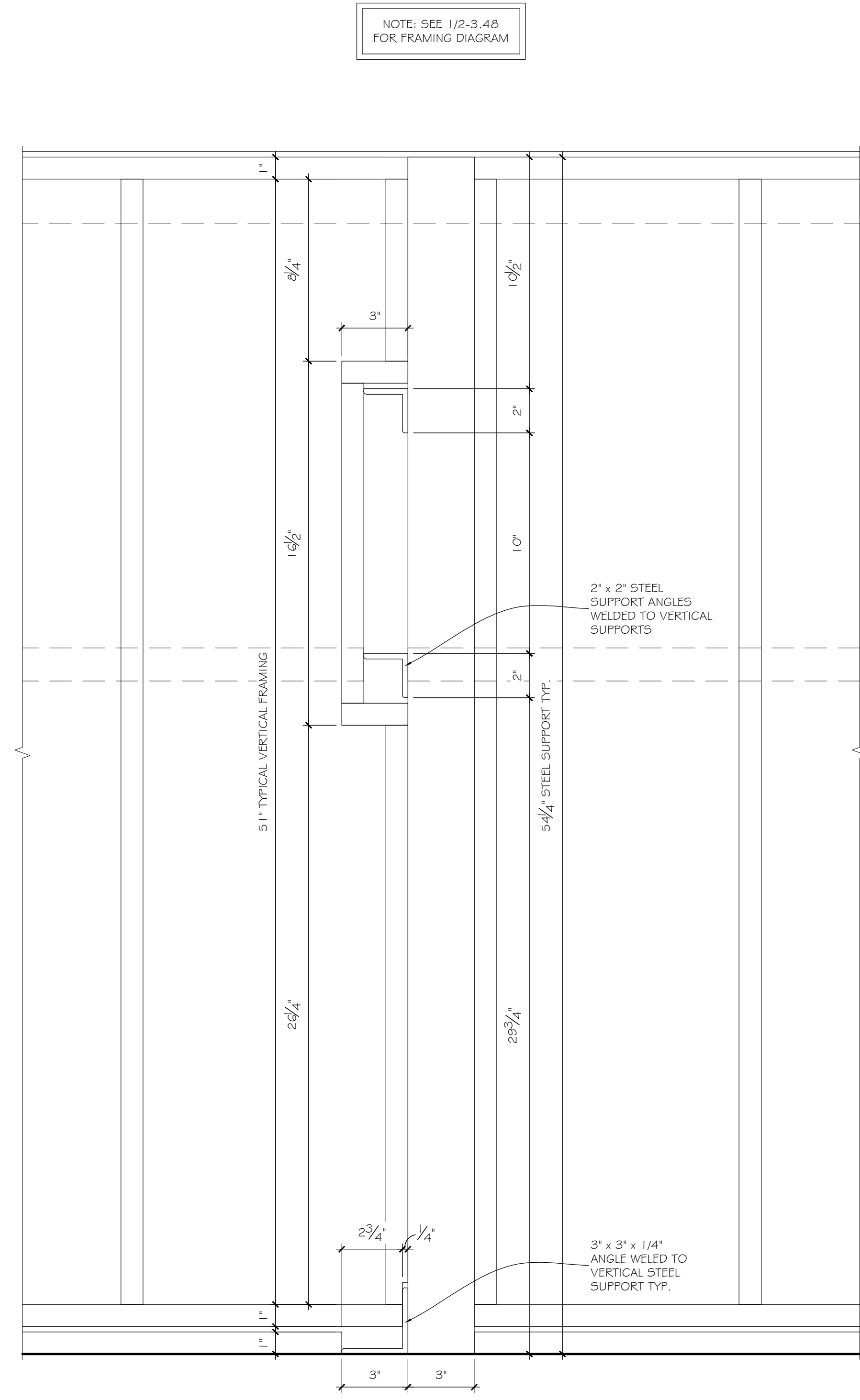
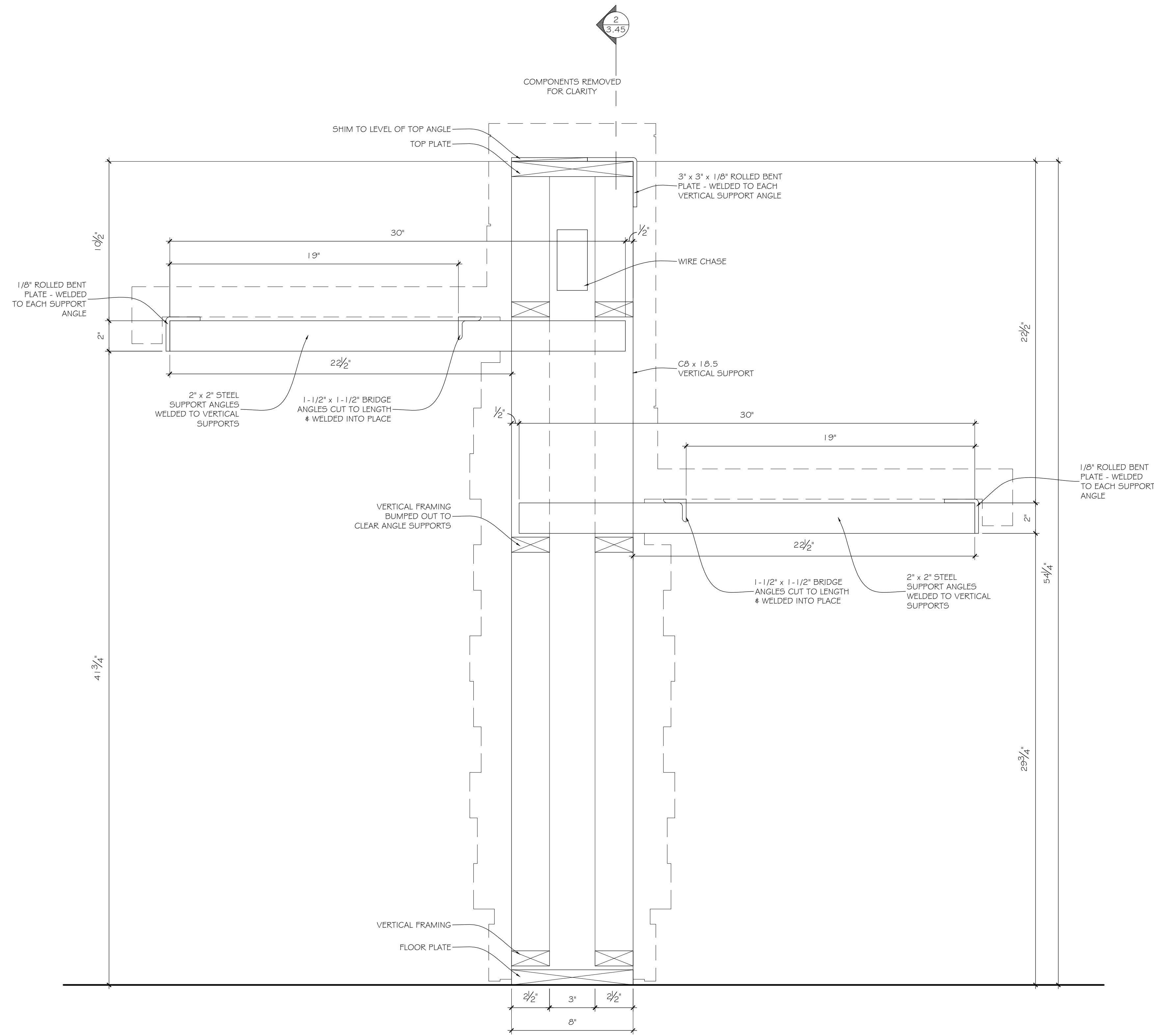

NOTE: SEE 1/2-3.48 FOR FRAMING DIAGRAM

INSTITUTIONAL

blacks outsourcing, inc.
Architectural Woodwork Engineering
Our business is drawing yours

2-3.45

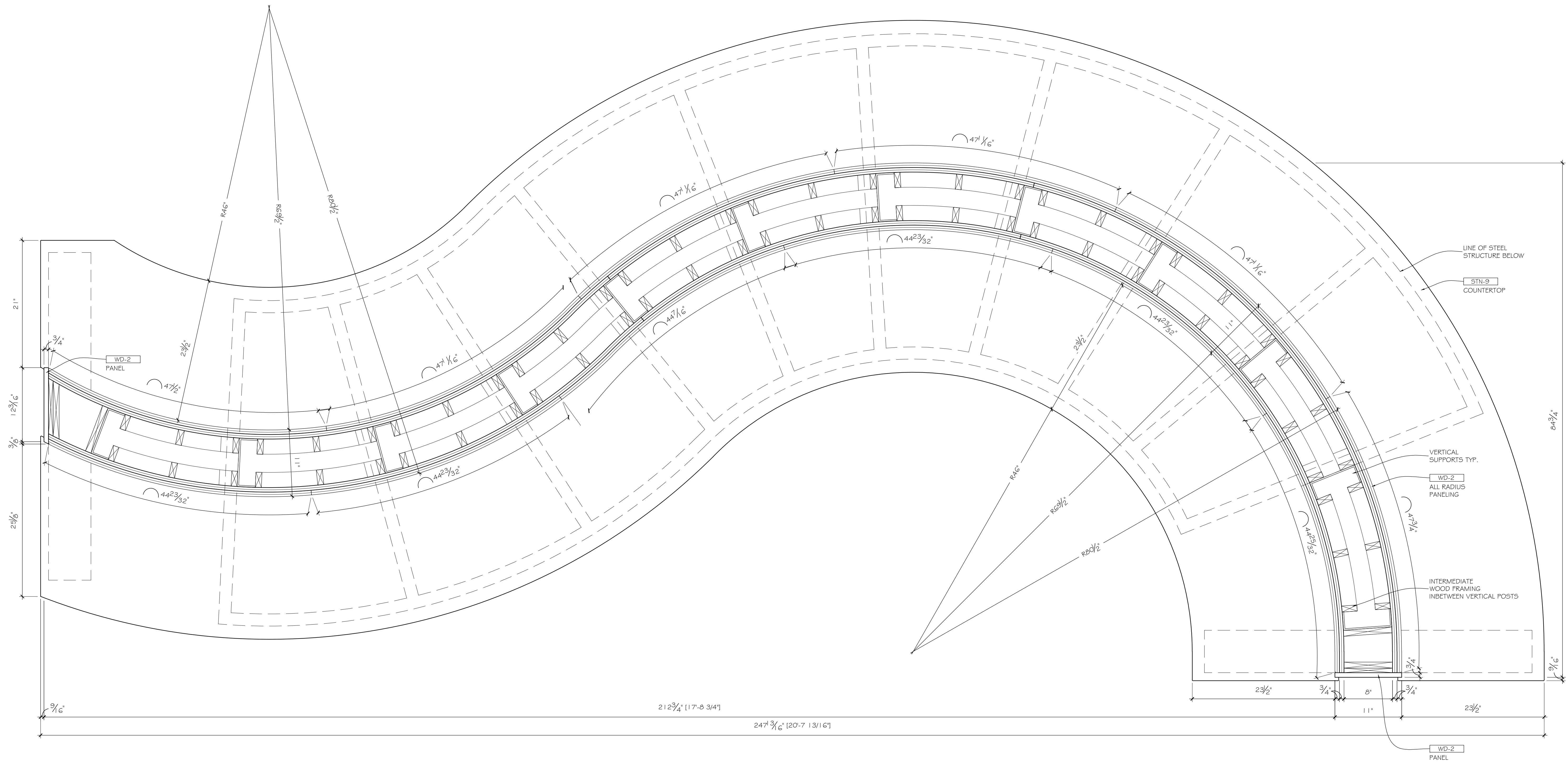

1 PLAN SECTION:
3.46 SCALE: 1-1/2"=12" ARCH. REF.: NONE

INSTITUTIONAL

blacks outsourcing, inc.
Architectural Woodwork Engineering
Our business is drawing yours

2-3.46

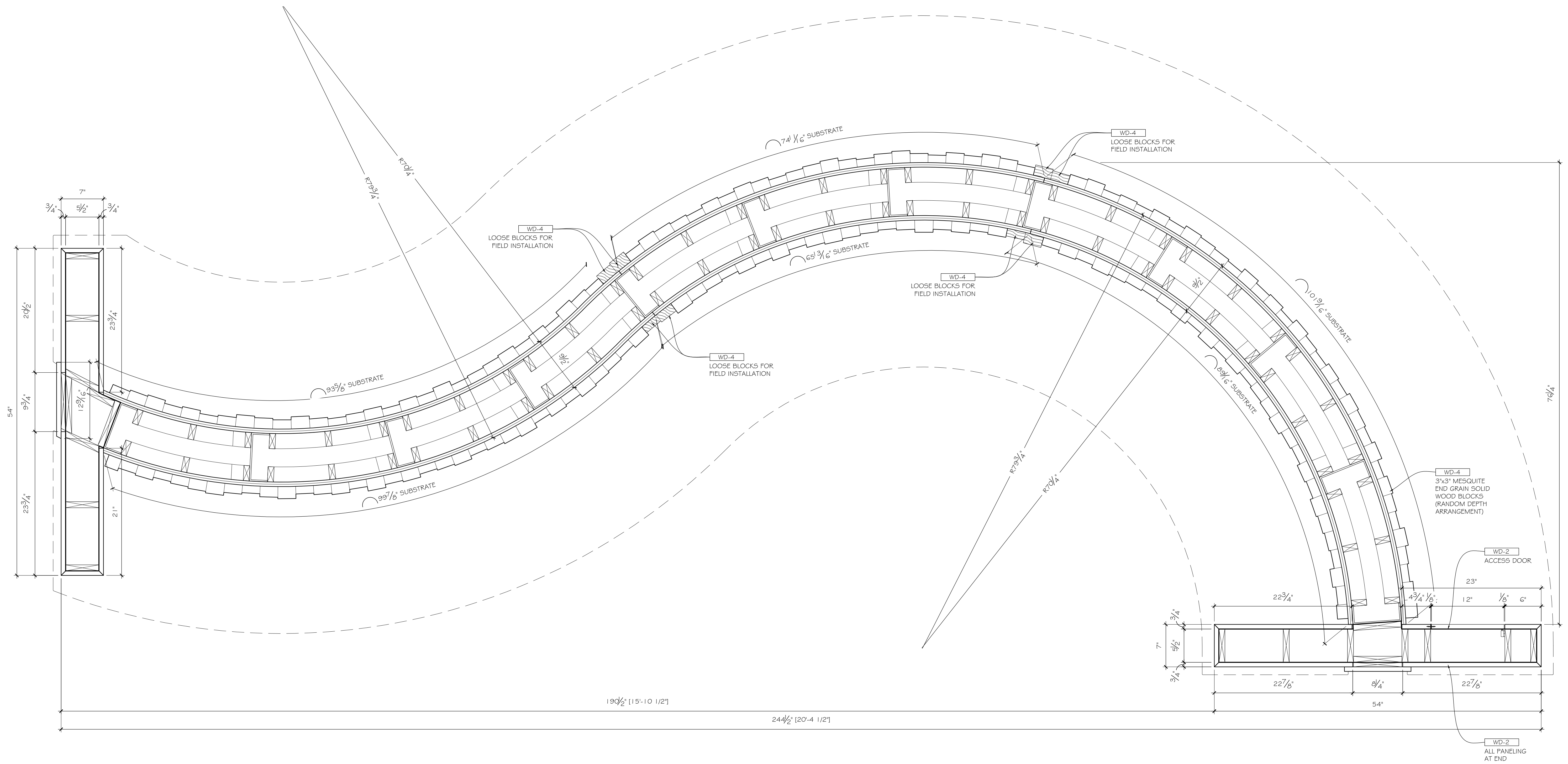

1 PLAN SECTION:
 3.47 SCALE: 1-1/2"=1' ARCH. REF.: NONE

INSTITUTIONAL

blacks outsourcing, inc.
 Architectural Woodwork Engineering
 Our business is drawing yours

2-3.47

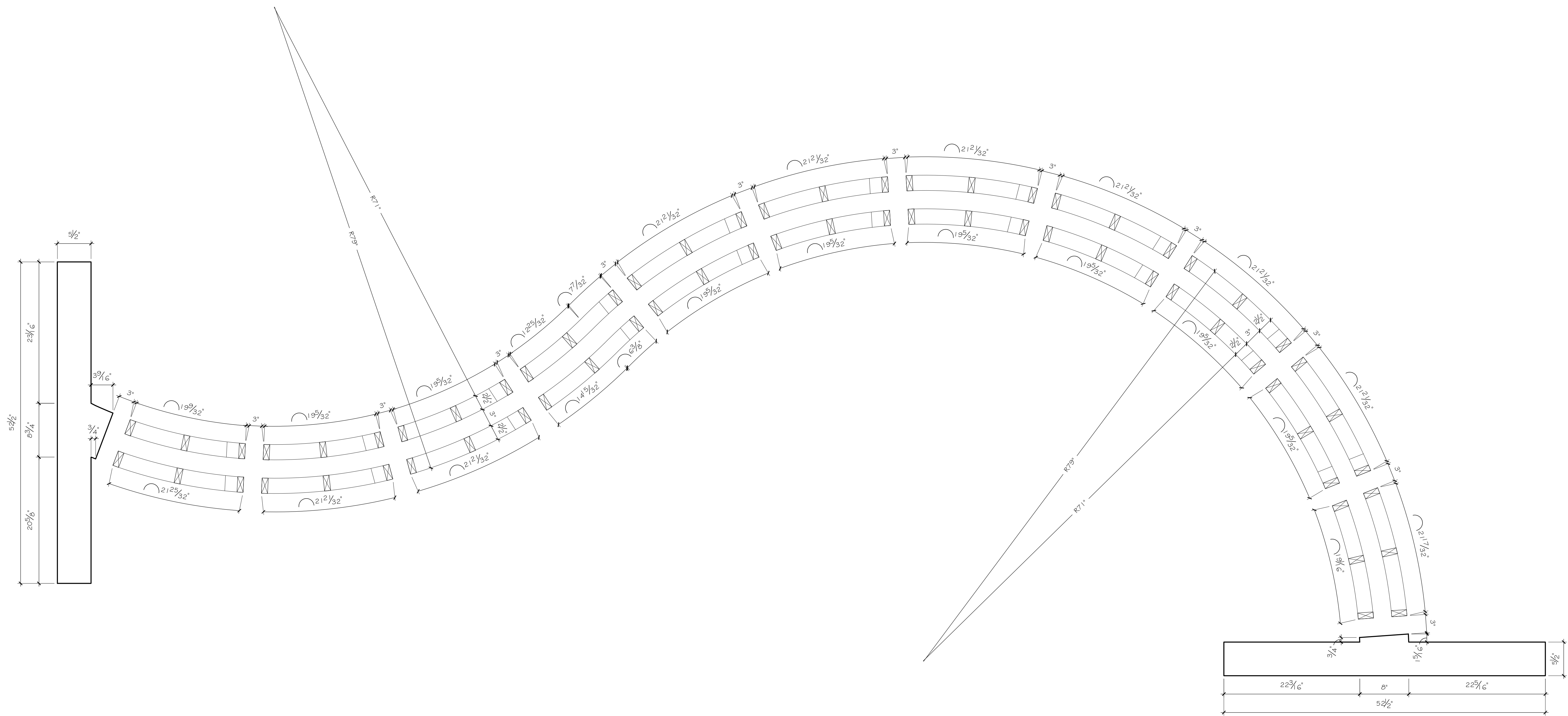

1 PLAN: INTERMEDIATE FRAMING DIAGRAM
 3.48 SCALE: 1-1/2"=12" ARCH. REF.: NONE

INSTITUTIONAL

blacks outsourcing, inc.
 Architectural Woodwork Engineering
 Our business is drawing yours

2-3.48